



---

## **DaNI-K: A Vision-based Robot Control Experiment with a DaNI Robot and Kinect Sensor Bundle**

**Dr. Nebojsa I Jaksic P.E., Colorado State University, Pueblo**

Nebojsa I. Jaksic received the Dipl. Ing. degree in electrical engineering from Belgrade University in 1984, the M.S. in electrical engineering, the M.S. in industrial engineering, and the Ph.D. in industrial engineering from the Ohio State University in 1988, 1992, and 2000, respectively. From 1992 to 2000 he was with DeVry University in Columbus, OH. In 2000, he joined engineering department of Colorado State University-Pueblo, where he is currently a professor and the acting department chair. Dr. Jaksic's interests include manufacturing processes, automation, robotics, and nanotechnology education and research. He is a member of ASEE, IEEE, SME, and MRS.

# **DaNI-K: A Vision-based Robot Control Experiment with a DaNI Robot and Kinect Sensor Bundle**

## **Abstract**

This work describes an implementation of a vision-based robot control experiment using a DaNI-K robot consisting of a DaNI 2.0 robot and a Kinect for Xbox 360 motion sensor package as a part of an upper-level required undergraduate mechatronics engineering robotics course. DaNI-K was created to be the next level robotic platform in comparison to the popular Mindstorms NXT robotic system. DaNI 2.0 is a 3-wheeled pre-assembled mobile robot based on National Instruments' Single-Board Reconfigurable I/O (sbRIO) and Pitsco Education's TETRIX Building System. SbRIO is an embedded control and acquisition board consisting of a real-time processor, an FPGA, and a number of I/O's that can be programmed in LabVIEW, a graphical programming language. The TETRIX Building System is a kit of aluminum parts, DC motors, gears, and wheels for building robotic hardware platforms. Kinect for Xbox 360 (Kinect) is a popular motion sensor package for the Xbox 360 video game console from Microsoft consisting of a 3D camera (depth sensor), color camera, and an array of microphones. The experiment included two tasks. The first task was to install all the necessary software and program the DaNI robot to perform obstacle detection and avoidance using its ultrasonic sensor. The second task was to improve the obstacle detection and avoidance capabilities of the DaNI robot by adding another computer connected to a Kinect sensor. Working in pairs and as a collective, students were able to complete the two tasks, develop their design/programming skills, and learn about some complexities of "real" engineering projects. In addition, they gained a better understanding of sensors and their applications including sensor fusion.

## **Introduction**

Many educational institutions, both formal and informal, have implemented LEGO NXT Mindstorms robotic kits to support science and engineering education. The great popularity of these kits stems from their affordability and flexibility. However, some engineering students feel overexposed to this product. Also, NXT Mindstorms kits are often incapable of performing more complex robotic tasks. To step up from NXT Mindstorms robots, universities are selecting more advanced robotic platforms. At our institution, NI LabVIEW Robotics Starter Kit for Education 2.0 (DaNI) is selected as the robotics platform for upper level undergraduate engineering courses. This decision is made to support scaffolding. Namely, engineering students are already familiar with the LabVIEW programming environment used with NI ELVIS workstations and to a limited degree NXT Mindstorms. DaNI uses a more powerful hardware platform while keeping the LabVIEW programming environment. The addition of a Kinect for Xbox 360 sensor motion package and a fit-PC2 greatly enhances the capabilities of the robot (DaNI-K).

## **Previous Work**

The importance of laboratory experiments and projects in engineering education can be justified by various learning theories. In this case, the justification comes from Kolb and his theory of learning called "Kolb's Experiential Learning Cycle." According to Kolb<sup>1</sup>, regardless of the learning style, people learn best if they follow a cycle consisting of four steps (axes):

experiencing (concrete experience), watching (reflective observation), thinking/modeling (abstract conceptualization), and applying/doing (active experimentation). Thus, active experimentation is an essential part of the learning process. Kolb's learning cycle has been used in various engineering education programs such as civil<sup>2-4</sup>, mechanical<sup>4</sup>, chemical<sup>2, 3, 5</sup>, industrial<sup>6</sup>, aeronautical<sup>4</sup>, and manufacturing<sup>2, 3, 7</sup> engineering.

The success of robotics projects in engineering education has been well reported in literature. The advanced robotics system described in this work is based on the newest hardware and software robotics and electronic entertainment platforms. NI LabVIEW Robotics Starter Kit for Education 2.0 was just released in August 2011<sup>8</sup> while the NI LabVIEW Robotics software module received a critical upgrade January 15<sup>th</sup>, 2012. On November 4<sup>th</sup>, 2010, Microsoft launched Kinect for the Xbox 360 console, and by mid-January of 2012 sold over 18 Million units<sup>9</sup>. However, Microsoft only released the Kinect Software Development Kit (SDK) for noncommercial use (Beta 2) in August 2011. Microsoft released Kinect for Windows with an SDK license on February 1<sup>st</sup>, 2012<sup>10</sup>.

To facilitate the use of DaNI in engineering education, King<sup>11</sup> developed a set of six laboratory exercises and tutorials. A program runs an obstacle detection and avoidance algorithm using an ultrasonic sensor, PING))), mounted on a servo motor. Norris<sup>12</sup> describes a robotics control project using the Kinect sensor, the Parallax wooden Robot Base Kit with Parallax Motor Mount and Wheel Kit, the Kinect SDK, C#, and a Windows Presentation Foundation (WPF) user interface. Finally, DaNI and the Kinect were used in an obstacle avoidance experiment<sup>13</sup>. However, this implementation uses a hacked LabVIEW driver for the Kinect and some "unreleased software from the LabVIEW Robotics Module," thus, it would be hard to implement in the classroom.

## **Curricular Context**

The experiment described in this work is implemented in a required robotics course at our university in the ABET accredited Bachelor of Science in Engineering with Specialization in Mechatronics (BSE-Mechatronics) program. The robotics course is a senior-level design-based course dealing with robotic topics such as robotic kinematics, dynamics, robot controls and sensors. It is intended to enable students to design, control, and maintain robots and robotic-based systems. One of the course outcomes is to enable students to design and implement small robotics projects using laboratory robots, sensors and interfaces. This outcome is in line with the ABET Criterion 3, student outcomes a, b, c, d, e, g, and k<sup>14</sup>. The robotics laboratory curriculum includes hands-on experiences where students design, build, and control various robots. Programming of industrial robots is accomplished with industrial grade robots extensively used in automation for material handling applications. In this study, we concentrate on the experience of programming of a mobile robot using the LabVIEW Robotics Starter Kit DaNI and connecting a Kinect sensor console to it via an additional computer, a fit-PC2. This laboratory exercise is developed to enable students to learn and to enhance their problem-solving and programming skills using familiar design situations. Students learn by developing their skills based on their previous experiences (scaffolding). Namely, they used LabVIEW in previous courses. Also, they built and programmed Mindstorms NXT robots in their freshmen year.

After a general class discussion of various sensors and their applications in algorithmic decisions based on multiple sensor inputs (sensor fusion), the students are introduced to two specific

sensors in detail: the ultrasonic sensor used with the DaNI robot and a novel 3D depth sensor (a part of the Kinect sensor bundle). Then, some rudimentary strategies of obstacle detection and avoidance are presented. Finally, the students are presented with the two laboratory tasks described below.

To aid others in the implementation of this lab, a detailed description of the robot hardware and software is provided next. Also, the description with some specific challenges illustrates the complexity of this laboratory exercise exemplifying what engineers often encounter in a workplace.

### DaNI-K Hardware Setup

Figure 1 represents a block diagram of the DaNI and Kinect hardware experimental setup (DaNI-K). A miniature PC (fit-PC2<sup>15</sup>) runs LabVIEW 2011, LabVIEW FPGA Module, LabVIEW Real-Time Module, LabVIEW Robotics Module, and the Kinect SDK on Windows 7. The PC is connected to DaNI via an Ethernet cable (RJ-45). Also, the PC is connected to the Kinect sensor via a USB cable. DaNI consists of an NI Single-Board Reconfigurable I/O (sbRIO-9632) embedded controller, a TETRIX robotic hardware platform with a dual DC motor controller, two DC motors with encoders, and a PING))) ultrasonic sensor mounted on an R/C-type servo motor. The sbRIO is comprised of a 2M gate Xilinx Spartan FPGA, 400 MHz Freescale real-time processor, 128 MB DRAM, 256 MB nonvolatile storage, RS232 serial port for peripheral devices, 110 3.3 V (5 V tolerant/TTL compatible) digital I/O lines, 32 single-ended/16 differential 16-bit analog input channels at 250 kS/s, four 16-bit analog output channels at 100 kS/s, and a 10/100BASE-T Ethernet port. The sbRIO can be programmed in a combination of programming languages like LabVIEW, LabVIEW MathScript, VHDL, and ANSI C. The TETRIX Building System consists of aluminum parts, DC motors, gears, and wheels for building robotic hardware platforms. Figure 2 is a photograph of DaNI with an ultrasonic sensor mounted on top of a servo motor.

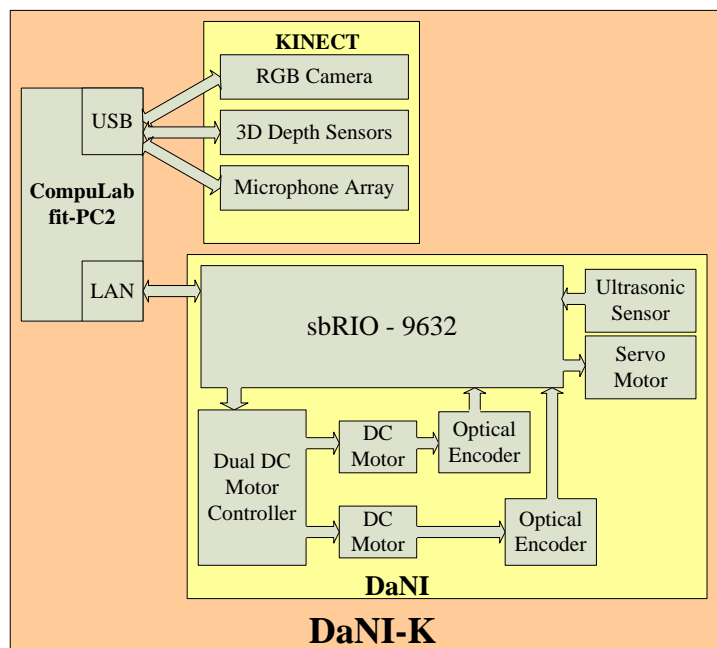

Figure 1. DaNI-K Robot Hardware Block Diagram

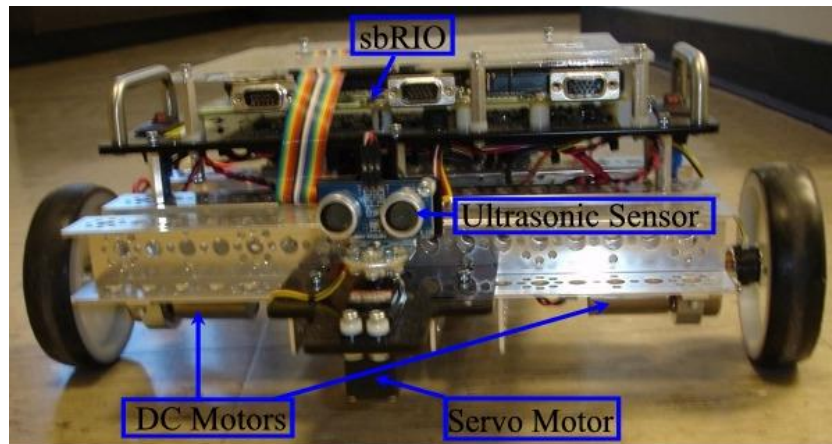

Figure 2. DaNI with Mounted Ultrasonic Sensor

Figure 3 is a photograph of a fit-PC2. Fit-PC2 is a miniature PC weighing about 13 ounces (370 grams) and having dimensions 4" x 4.5" x 1.05" (101 x 115 x 27 mm). This small factor PC based on the Intel Atom Z530 1.6GHz CPU is capable of running Windows 7. Also, the six USB 2.0 ports, one 1000-BaseT Ethernet port, and an 802.11n WLAN port provide sufficient I/O's for connecting the Kinect sensor (requires a USB port) and for connecting the sbRIO of the DaNI robot (requires an Ethernet port). The 12V power supply shipped with the computer is replaced with a 12V battery pack for autonomous robot operation.

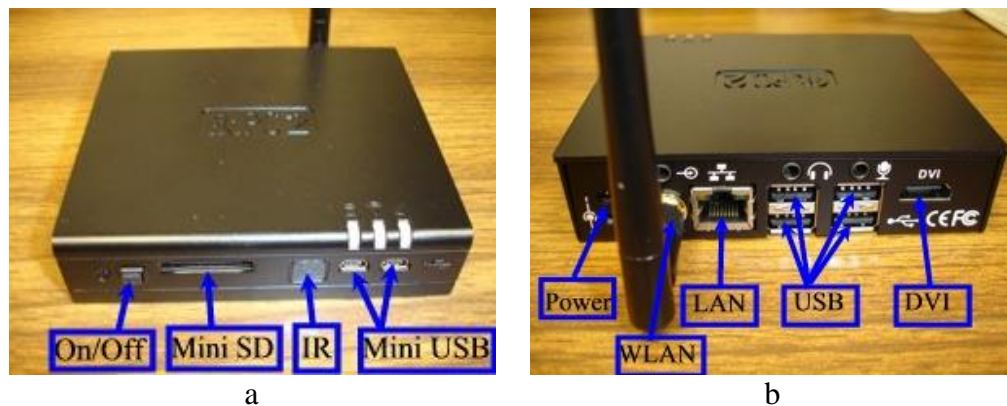

Figure 3. Fit-PC2, front (a) and back (b)

Figure 4 shows the front view of a Kinect for Xbox 360. This is a remarkable and inexpensive set of sensors housed in a single package. The Kinect sensor bundle includes a novel 3D depth sensor for discerning 3-dimensional information about the robot surroundings, an RGB camera for remote vision-based control and first person vision (FPV) applications, an array of microphones for acoustic source localization, a 3D accelerometer for motion sensing, and an electric motor for programmable tilting of the entire sensor bundle. The 3D depth sensor consists of an infrared laser projector coupled with a monochrome camera (640 x 480 pixels with 2Kb resolution per pixel). While not well documented, it seems that the laser uses speckle (a pseudorandom pattern of dots created by shining light through a micro-patterned plastic lens) to

project a number of specs which the monochrome camera captures. Then this image is compared to a template image. The difference in position between two corresponding specs in two images can be interpreted as the distance of the point on the object from the sensor. The Kinect ships with a power adapter. In this laboratory exercise the power adapter is replaced with a 12V battery pack for autonomous operation of the robot.

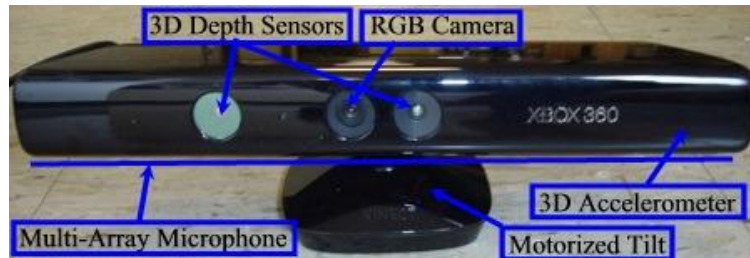

Figure 4. Kinect for Xbox 360 Sensor Package

### DaNI-K Software Setup

All the software for DaNI-K is installed on four laboratory laptops (for DaNI-K program development) as well as on a fit-PC2 mounted on DaNI-K (for final testing). Installation of four software packages is performed in preparation for this experiment: (1) Windows 7 Enterprise Edition 32-bit version; (2) LabVIEW 2011 with LabVIEW Robotics Starter Kit, LabVIEW Run-Time Module, LabVIEW FPGA Module, and appropriate drivers; (3) Kinect for Windows SDK, and (4) Kinect LabVIEW Interface.

Prior to this experiment, Windows XP was installed on all laboratory laptops because the University's Information Technology (IT) department does not support Windows 7. However, since one of the software suites used in this lab requires Windows 7, this operating system (OS) is installed on all laptops. First, Windows 7 drivers are downloaded to jump drives from Dell's website (Laptop model: Precision M4600). Then the laptops are rebooted with the Win 7 installation DVDs, HDs formatted, and the OS (Windows 7 Enterprise edition 32-bit) installed. After the OS installation, the appropriate drivers are installed from the jump drives. After rebooting, all drivers, including the wireless network driver, become available. Then, the drivers are enabled, one by one, using the following procedure. Click (or double-click) on <start menu>, <devices and printers>, <computer icon>, <hardware>, <device to be enabled>, in the [General] tab <change settings>, change tab to [Driver], click <Update Driver>, <Browse my computer...>, choose the directory where the drivers are installed, e.g. <C:\laptops\_dell\drivers>, click <OK>, and <Next>. When done, close all opened windows and reboot.

However, to connect the laptops to the University wireless network for the OS activation and further software downloads, the laptops must be registered with the IT department, on-line. The IT department requires laptops' MAC addresses which are obtained by going to the Start Menu, typing "cmd" in the "Start Search" bar to start the Command Prompt window, and then typing "getmac /v." The "Physical Addresses" are the MAC address of the wireless network cards. After connecting to the University wireless network, the OS is activated by going to <Start Menu> <Control Panel> <All Control Panel Items> <System>, and then, clicking on <Change product key> on the bottom of the window and entering the key. As a matter of policy, after

every software product installation, laptops are rebooted. If this is overlooked, often, the software may not behave as expected.

With the laptops connected to the wireless network, the LabVIEW 2011 software suite from National Instruments (NI) is installed. The suite includes LabVIEW 2011 Professional, LabVIEW FPGA Module, LabVIEW Real-Time Module, LabVIEW Robotics Module, and NI Vision Module. Options dealing with sbRIO (the embedded hardware platform running DaNI) are included as choices during the installation of the LabVIEW 2011 core as well. A set of DVDs is used to install the above modules. The installed modules are activated using the department's academic license key. The LabVIEW 2011 Robotic Module allows testing of DaNI robot (individual motors, the ultrasonic sensor, and the autonomous operation with obstacle avoidance). However, DaNI has problems with some obstacles caused by the type of sensor used, i.e., approaching a wall at a sharp angle. To increase the sensor range and sensitivity, as well as to provide a visual feedback of the environment a Kinect sensor is integrated with the robot using an additional mini computer.

The Kinect for Windows Software Development Kit (SDK) v1.0 Beta 2, the version for the 32-bit Windows 7, is downloaded from Microsoft's Download Center website. The readme file (downloaded from the same site) reveals a number of software requirements with appropriate links. Thus, prior to the Kinect SDK installation, the following software packages are installed: Microsoft Visual Studio 2010 Express (both C++ and C# version), Microsoft DirectX SDK – June 2010, Runtime for Microsoft DirectX 9, Microsoft Speech Platform Runtime – version 10.2, Microsoft Speech Platform SDK – version 10.2, and Kinect for Windows Runtime Language Pack – version 0.9. The program .NET Framework 4.0 is not installed separately, because it is a part of the Microsoft Visual Studio 2010 Express installation. Then, the included three sample programs (Kinect Audio Demo, Shape Game, and Skeletal Viewer) are executed to verify correct installation.

Finally, a set of Virtual Instruments (VIs) grouped into the Kinect LabVIEW Interface is downloaded from the NI Developer Zone. However, after the installation, the included demo program, Kinect Demo, did not execute correctly. After careful observation it was realized that the Kinect LabVIEW Interface program was published on September 16, 2011 which was before the Microsoft Kinect for Windows SDK v1.0 Beta 2 was released (November 4<sup>th</sup>, 2011). The problem was traced to the older version of the file Microsoft.Research.Kinect.dll (ver. 1.0.0.11) included with the Kinect LabVIEW Interface. The solution consists of two steps. First, all the copies of the older file are replaced with copies of the new file included in the Microsoft Kinect for Windows SDK Beta 2 (ver. 1.0.0.45). Then, in the Initialize Kinect VI, the Runtime .NET constructor (the first Runtime block from the left in the Initialize Kinect VI Block Diagram) is reconfigured (double-click on Runtime block) by changing the Assembly option to point to Microsoft.Research.Kinect.dll (ver. 1.0.0.45), as depicted in Figure 5.

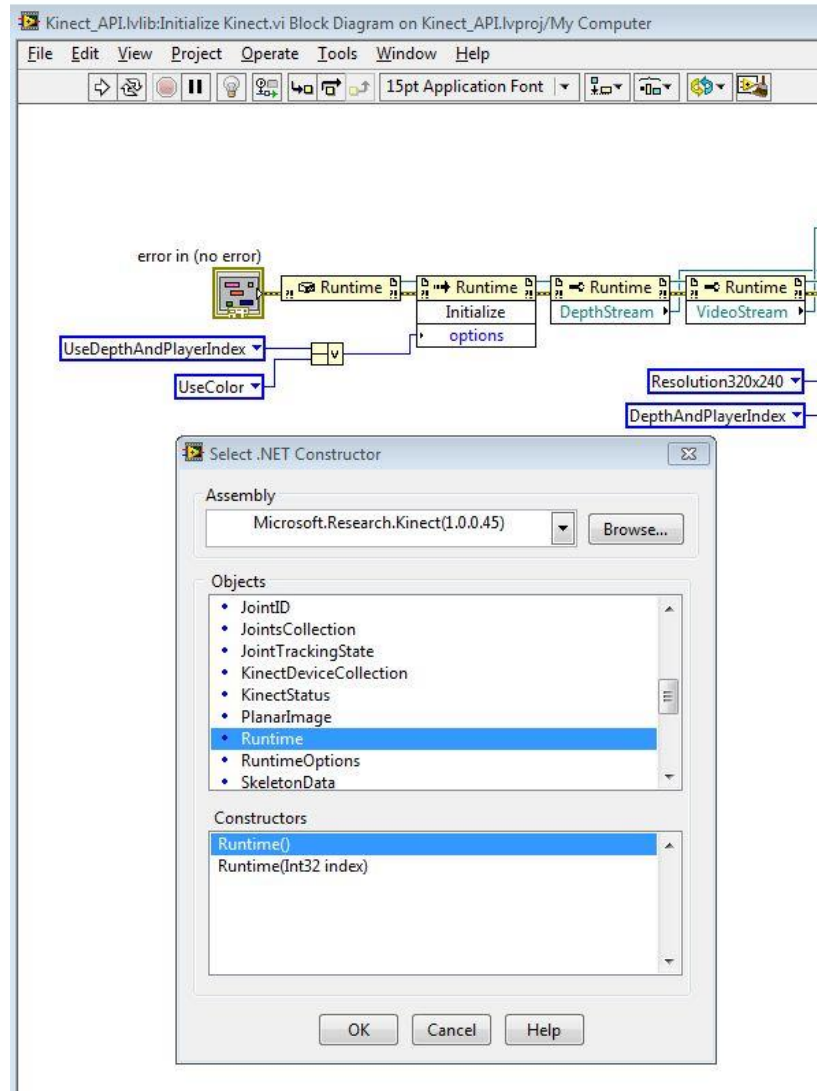

Figure 5. Screen Shot of Initialize Kinect VI Runtime .NET Constructor Change

## Procedure

At the beginning of the lab, students are encouraged to explore the 3D-module of the TETRIX robotic platform through Pitsco's license of the Parametric Technology Corporation (PTC) Creo Elements/View Express<sup>16</sup>, a 3D modeler/viewer (downloadable free software). A screen shot of the TETRIX robotics base is shown in Figure 6.





Figure 6. Creo Elements/View Express Screen Shot of the TETRIX Robotics Base

The first sample program for DaNI that is included in the National Instruments' LabVIEW Robotic Module is the obstacle avoidance program. After installing the appropriate programs described in the DaNI-K Software Setup section, loading the sample program to sbRIO, disconnecting DaNI from the development PC, and placing DaNI on the floor, the DaNI MOTORS switch is turned on, and the robot is left to roam around. Figure 7 shows DaNI roaming a hallway of the University, detecting a chair leg and trying to avoid it. The servo motor that controls orientation of the ultrasonic sensor rotates left and right allowing the ultrasonic sensor to detect obstacles and DaNI to avoid them.



Figure 7. DaNI Navigating a Hallway

However, on occasion, the DaNI robot was not able to detect and avoid an obstacle on its way. This is a direct consequence of an ultrasonic sensor limitation due to its mode of operation. The ultrasonic sensor consists of an ultrasonic transmitter and a receiver. When the sensor is active, the sensor's transmitter emits high frequency sound pulses (40 KHz). Then, when the sensor's receiver detects the pulses reflected from an object the robot detects the object and determines the object's distance from the sensor by measuring the time between the transmitted and received pulses. However, due to the shape of some of the object's features (sharp angles), the reflected

sound waves do not always reach the receiver. As a result, such an object is not detected. Sometimes, the DaNI robot could not detect a leg of a chair or even a wall if the wall was approached at a sharp angle. To cope with such obstacles, a Kinect sensor with an accompanying fit-PC2 was added to the robot. The complete laboratory setup including a DaNI robot, a fit-PC2, and a Kinect sensor is depicted in Figure 8, while a hardware connection block diagram is shown in Figure 1. According to Table 1, the cost of the laboratory setup hardware is about \$2,200. Since LabVIEW (\$2,050 academic license per year) and Windows 7 are used in other courses they don't have to be included in the total cost of the project.

Table 1. Laboratory Setup Cost

Part	Cost (\$)
National Instruments DaNI robot	1,650
CompuLab fit-PC	350
Microsoft Kinect for Xbox 360 sensor pack	200
National Instruments LabVIEW academic license per year	2,050*
Microsoft Windows 7 operating system (est.)	100*
<b>Total</b> (not including software)	<b>2,200</b>
<b>Total</b>	<b>4,350</b>

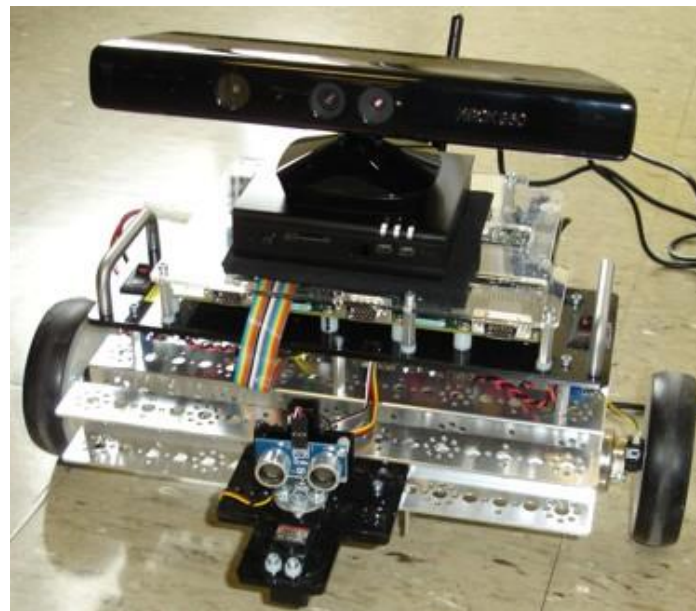

Figure 8. Complete DaNI-K Robot

## Results

Even though the first laboratory task of understanding DaNI, installing the development software, working with an embedded platform connected to a development laptop via an Ethernet cable, loading the sample obstacle avoidance program, calibrating the ultrasonic sensor, and operating the robot was complex, the students were successful in achieving this task with

minimal help from the instructor. Sometimes, the development laptop did not recognize the robot. The problem was traced to insufficiently charged robot batteries.

The second task of connecting a Kinect sensor to the robot via a fit-PC2, and programming the robot with the downloaded Kinect drivers was not as complex, but it was much harder. The students required help in installing the correct Kinect drivers. The problem and the solution were presented earlier in the DaNI-K Software Setup section. While the students did spend a considerable amount of time on programming the Kinect sensor to aid in obstacle avoidance, they were successful. They used the sample program as a base for their additions.

### Assessment and Evaluation of Student Learning

A simple instrument was developed to measure how much students learned about specific sensors and their application for obstacle detection/avoidance tasks in mobile robotics within this teaching module. The instrument was administered and the results evaluated for one group of students. The instrument consists of two tests, a pre-test and a post-test. The tests were administered before the start of the teaching module, and immediately after the lab experience. The tests were graded from 1 to 5, where 1 means the answer is missing or is wrong, while 5 means the answer is complete and accurate. The results of the two tests as well as the test questions are shown in Table 2. The table includes student test score averages per question for the two tests on a scale from 1 to 5, and the difference (in percent) between the two. Eight students participated in the assessment process.

Table 2. Obstacle Detection/Avoidance and Sensors Test

Num.	Question	Pre-test	Post-test	diff (%)
1	What is an ultrasonic sensor?	3.33	4	16.75
2	How does an ultrasonic sensor work?	2.67	4	33.25
3	Describe at least two different obstacle avoidance algorithms.	1.33	4.75	72.00
4	How does the Kinect's 3D depth sensor work?	1.33	4.75	72.00
5	What is the main disadvantage of ultrasonic sensors when used in obstacle avoidance tasks?	2.17	4.75	54.32
6	When is it appropriate to use sensor fusion?	2	4.63	56.80

The results show a gain in students' knowledge of sensors and obstacle avoidance algorithms. However, the instrument is simple, only measures the differences in factual knowledge, and is administered to too few students to allow any meaningful statistical analysis. In addition, the influence of the lab experience in the knowledge gain is not separated from the lecture portion of the course.

Informal interviews with students revealed that they had a positive experience working with DaNI-K. They were proud of their accomplishments and felt like engineers. They believe that their programming skills with LabVIEW improved.

When the course is offered next time, another group of students will be exposed to this module and the results may be statistically significant. The informal interviews will be changed to a formal questionnaire on students' perception of the laboratory experience. In October of 2012, an updated version of the Kinect SDK became available, so it will be implemented.

## Conclusions

In this paper, a DaNI robot is integrated with a fit-PC2 running Windows 7 and a Kinect for Xbox 360 motion sensor package to create a DaNI-K robot. The robot is programmed using LabVIEW and the Kinect SDK to successfully avoid obstacles on its way while it wanders. The experiment included two tasks: (1) the software installation and programming of the DaNI robot to perform obstacle detection and avoidance using its ultrasonic sensor and (2) improving the obstacle detection and avoidance capabilities of the DaNI robot by a Kinect sensor. While the first task could be considered an easy one where the students were only to follow instructions for software/hardware installation, this was not the case. The multiple-software installation was fairly complex and cumbersome due to some incompatibilities between software versions. After the successful software installation, the connection between the robot and the programming computer proved unreliable. After careful observation it was discovered that the robot would not connect to the computer anytime its batteries were low. This problem was solved procedurally, i.e., before each use the robot batteries were charged. When the robot, in its obstacle avoidance mode, was left to roam the lab it would sometime run into a chair leg or a wall. This behavior was attributed to the obstacles' sharp angles making such obstacles hard to detect by the robot's ultrasonic sensor. So, the second task, the use of the Kinect sensor bundle, represents a solution to the problem caused by the robot's ultrasonic sensor design flaw.

Students were able to realize the above mentioned two tasks. In the process, they increased their knowledge of sensors and sensor applications such as sensor fusion while they improved their design/programming skills. Students were pleased with the knowledge and skills they gained.

## Bibliography

1. Kolb, D. A., *Experiential Learning: Experience as the Source of Learning and Development*, Prentice Hall, Englewood Cliffs, N.J., 1984.
2. Harb, J. N., Durrant, S. O., and Terry, R. E., "Use of the Kolb Learning Cycle and the 4MAT System in Engineering in Education," *Journal of Engineering Education*, Vol. 82, April 1993, pp. 70-77.
3. Harb, J. N., Terry, R. E., Hurt, P. K., and Williamson, K. J., *Teaching Through The Cycle: Application of Learning Style Theory to Engineering Education at Brigham Young University*, 2<sup>nd</sup> Edition, Brigham Young University Press, 1995.
4. Ortiz, L. E. and Bachofen, E. M., "An Experience in Teaching Structures in Aeronautical, Mechanical and Civil Engineering, Applying the Experimental Methodology," *Proceedings of the 2001 American Society for Engineering Education Annual Conference & Exposition*, Session 2526.
5. Abdulwahed, M. and Nagy, Z. K., Applying Kolb's Experiential Learning Cycle for Laboratory Education, *Journal of Engineering Education*, July 2009, pp. 283-294.

6. Wyrick, D. A. and Hilsen, L., "Using Kolb's Cycle to Round Out Learning," *2002 American Society for Engineering Education Annual Conference and Exposition Proceedings*, Montreal, Canada, June 17-19, 2002. Session 2739.
7. Harding, T. S., Lai, H.-Y., Tuttle, B. L., and White, C. V., "Integrating Manufacturing, Design and Teamwork into a Materials and Processes Selection Course," *2002 American Society for Engineering Education Annual Conference and Exposition Proceedings*, Montreal, Canada, June 17-19, 2002. Session 1526.
8. Conrad, J. and Kerry, M., "LabVIEW Robotics Starter Kit (DaNI) Lab Exercises," Session TS5040, *NIWeek 2011*, Austin, TX, August 1-3, 2011.
9. Takahashi, D., "Xbox 360 surpasses 66M and Kinect passes 18M units," *GamesBeat Interpreting Innovation*, January 9, 2012. Accessed on January 5, 2013. from <http://venturebeat.com/2012/01/09/xbox-360-surpassed-66m-sold-and-kinect-has-sold-18m-units/>
10. Bridgwater, A., "New SDK for Microsoft Kinect Available Feb 1 2012," *Dr. Dobb's M-Dev*, January 17, 2012. Accessed on January 5, 2013. from <http://drdobbs.com/windows/232400416>
11. King, R., *Mobile Robotics Experiments with DaNI*, Accessed on January 5, 2013. from [http://download.ni.com/pub/devzone/epd/mobile\\_robotics\\_experiments.pdf](http://download.ni.com/pub/devzone/epd/mobile_robotics_experiments.pdf)
12. Norris, S., "K-SEE: A Robot that Sees the World Through a Kinect!" *Robot*, March/April 2012.
13. "Using the Xbox Kinect with LabVIEW Robotics Starter Kit," Accessed on January 5, 2013. from <https://decibel.ni.com/content/docs/DOC-15920>
14. Criteria for Accrediting Engineering Programs Effective for Reviews During the 2013-2014 Accreditation Cycle, ABET Engineering Accreditation Commission, 2012, Accessed on January 5, 2013. from [http://www.abet.org/uploadedFiles/Accreditation/Accreditation\\_Step\\_by\\_Step/Accreditation\\_Documents/CURRENT/2013\\_-\\_2014/eac-criteria-2013-2014.pdf](http://www.abet.org/uploadedFiles/Accreditation/Accreditation_Step_by_Step/Accreditation_Documents/CURRENT/2013_-_2014/eac-criteria-2013-2014.pdf)
15. Fit-PC2 Specifications, *CompuLab*, Accessed on January 5, 2013. from <http://www.fit-pc.com/web/fit-pc2/fit-pc2-specifications/>
16. TETRIX@ Builders Guide, Pitsco, Inc., 2012, pp. 181-183. Accessed on January 5, 2013. from [http://www.tetrixrobotics.com/RCBuildersGuide/files/resources/Print\\_All\\_TETRIX\\_BG.pdf](http://www.tetrixrobotics.com/RCBuildersGuide/files/resources/Print_All_TETRIX_BG.pdf)