

# MICROCONTROLLER CONTROLLED WALKING ROBOT

K.M. Fotouhi

Electrical Engineering Technology Department  
University of Maryland Eastern Shore

## Abstract

The objective of this project, funded by the ACTION Program at the University of Maryland Eastern Shore, was to involve and expose undergraduate students, particularly minority and under-represented students, in research and real-world projects. One of the unique aspects of this project was the involvement and collaboration of a graduating senior student as well as a freshman student during construction and application of the robot. This arrangement was intended to provide an opportunity for peer teaching and learning. The construction and operation of an advanced walking robot was intended to display the students' creativity and design abilities and to simulate a real world hands-on project. Students were expected to gain experience in controlling the movement of an Advanced Walking Robot (Toller Robot). To achieve the proper operation of a system, such as a robot, requires the harmony and coordination of many engineering disciplines. Students investigated the performance of the robot in relation to its environment and surrounding objects, the robot's walk radius and its space envelope, repeatability, safe operation, and its limitations.

The project was an educational experience that benefited the students involved, including the reinforcement of courses such as: Design Technology I, II, Feedback Control Systems, and Microprocessor courses. The use of optical sensors and the ISD2560 Voice Record/Playback with a Walking Robot gave the robot the ability to move away from obstacles or gave a warning message when the robot bumped into an object, making the project more interesting and challenging.

## Introduction

The ACTION Program at the University of Maryland Eastern Shore, that funded this project, required the involvement and participation of undergraduate students, especially minority and under-represented students, in research or real-world hands-on projects.

The purpose of this project was:

- To help students gain knowledge of controlling motions of a Walking Robot using a microprocessor.
- To bring together a graduating senior student with a freshman student in collaborative effort to assemble, program, and maneuver the walking robot.
- To enhance students' learning and knowledge, and enable the senior student specifically to apply the knowledge he had gained from courses such as: Design Technology I, II, and Feedback Control Systems and Microprocessor courses.

## Design Project Requirement

In this project, the two minority students involved were a graduating senior student and a second semester freshman. The freshman was paid by the ACTION Program for the time he spent on this project. The senior student was not paid, but the project was part of his design course assignment. Pairing these two students to work on this project was an experimental activity which enabled the research principal faculty to observe the peer teaching and learning challenges involved.

The project required students to assemble the first Toddler Robot kit together. After completion of the first kit, a second Toddler Robot kit was assembled by the freshman student only. The Toddler Robots were programmed using an on board Stamp2 Microprocessor to perform many routines. After students became familiar with the on board Microprocessor programming of the Toddler and its movement and limitations, the senior student was required to interface the Toddler with National Instrument Data Acquisition Board, so that he could program the Toddler Robot. The freshman student's activities were limited to the use of the on board microprocessor.

### **Assembling the Toddler Robot**

Two Toddler Robot kits were purchased from Parallax. Each student documented the time spent working in the laboratory together and the time spent working alone in the laboratory. Assembly of the Toddler Robot began with installing the servomotor installed on the body of the toddler. The kit included two motors: the Tilt and Stride Servos. The tilt servo was used for rotating the robots' center of gravity back and forth on both feet, while the stride servo moved both legs back and forth. The horns and brass wire keepers were installed on the servos, which were used for controlling the legs and feet of the toddler. The top plate was installed on the top of the body, which held the battery pack and the Stamp2 microprocessor board. After the top plate was put in place, the legs were attached to the body and secured tightly. The ankles and feet were then attached and controlled with tilting rods connected to the tilting servo and feet. Finally, the battery pack was mounted and the toddler board on the top plate was placed so that it would complete the assembly process. The Toddler Robot was ready for programming and testing its operation. At first, the programming of the robot was done by the senior student. As time passed, the freshman became more involved, was confident enough to

work alone on the project, and spent more time on the project. Figure 1 shows the circuit diagram of the Toddler Robot with Stamp2 microprocessor board. Figure 2 shows the Toddler Robot assembled and successfully programmed by the freshman.

Figure 3 shows the senior student's designed Interfacing circuit to move the toddler robot with the National Instrument Data Acquisition card. However, due to time constraints, it was determined that it was not practical to walk the Toddler Robot with so many wire attachments, because it would have required too many modifications.

Due to this complication, the senior student's design project was modified so that the Toddler Robot would be able to talk and have optical sensors to guide the toddler around obstacles. The Bumpers, also known as "Twinkle Toes," were purchased from Parallax, to protect the robot when it made contact with objects.

### **Program and Test**

Several routines were tested on the Toddler to ensure proper functions before the bumpers and sound module were installed. These programs were written in Basic Stamp2 by Parallax and were tested on the toddler:

- Forward Walking - Basic forward steps only
- Backward Walking - Basic back steps only
- Coordinated Walking - A routine where the robot took a few steps forward then turned and then took a few steps backward
- Turning Around - Simple pivot steps to turn the robot around

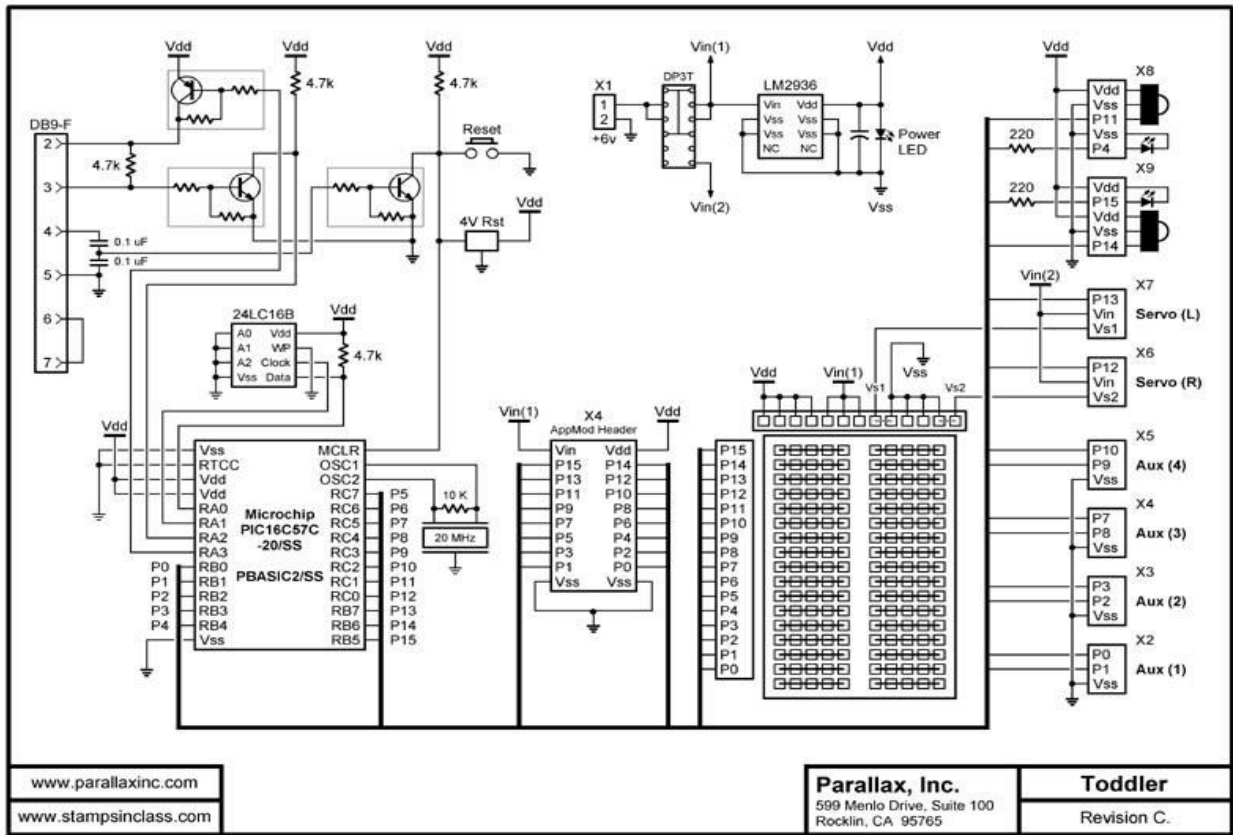

Figure 1. The Toddler Robot's circuit diagram along with Stamps2 Microprocessor Board from Parallax, Inc.

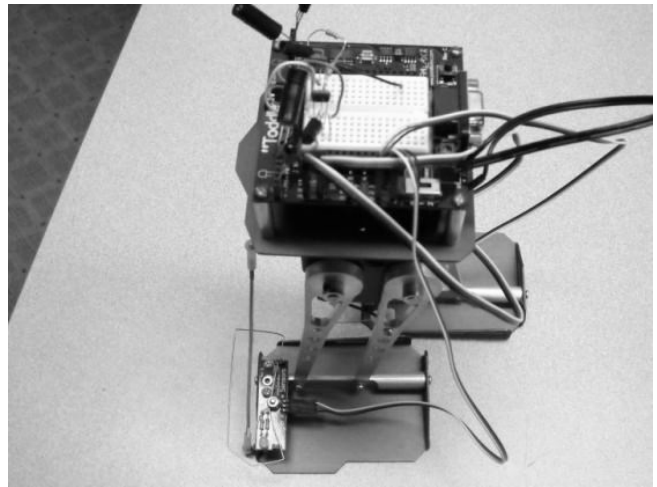

Figure 2. The Toddler Robot being assembled by the freshman.

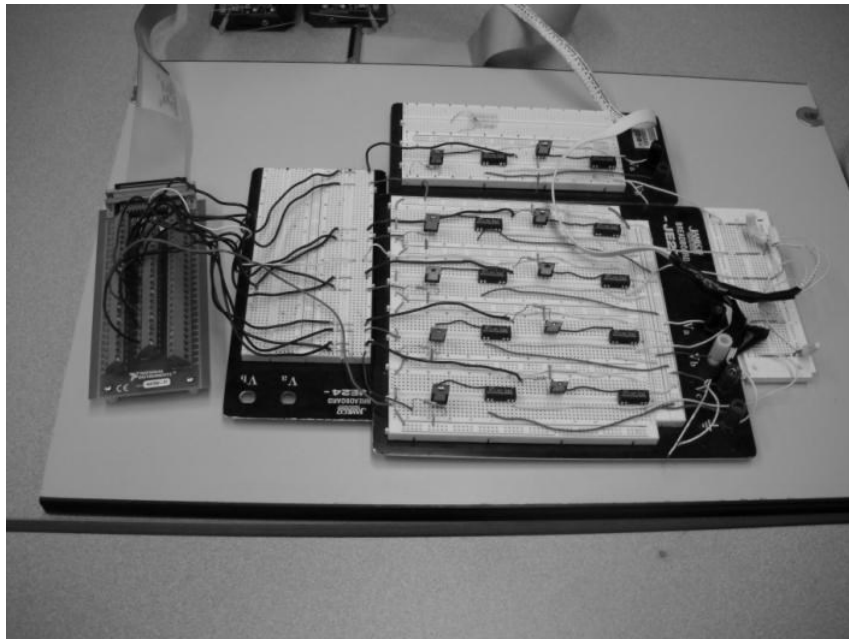

Figure 3. Interfaced Circuit to move Toddler with National Instrument Data Acquisition Card.

- Light Compass – The toddler pointed in the direction of the brightest part of the room with the help of two photo resistors, capacitors and resistors in a circuit
- Follow the Light – The Toddler followed a flashlight in the dark
- Object Detector – This was tested by using an infrared light to detect objects by the reflectance of the light to an object and staying away from that object
- Staying on the Table – Used infrared light to measure the frequency and detect the drop off zone

#### **Adding the Bumpers**

The wires for the bumpers were constructed first, and then connected to the sensor. The sensors were screwed onto both feet of the Toddler Robot. The Toddler was programmed so that when the bumpers came in contact with an object, the Toddler Robot would step back and change its direction of movement.

#### **Adding the Record/Playback**

The ISD2560 voice module was obtained from Technological Arts. The voice module was used as a stand-alone, and was activated by the two trigger pins that attach the sound module to the Walking Robot. Two brackets were constructed with thin metal, and a hole was drilled on both sides of the brackets to join one end of the bracket to the top plate of the Toddler Robot. The Toddler Robot was programmed to talk when it hit an object. The bumpers were also used to send signals to the sound module by triggering the playback on the ISD2560 when it encountered an object. Each time the bumpers made contact with an object, the sensors on the bumpers sent a triggering signal to the voice module. The module then triggered the recorded message of "OUCH," which was sent to the speaker attached to the metal bracket.

Figure 4 illustrates "Twinkle Toes" fully assembled. Figure 5 illustrates the completed Toddler Robot by the senior student.

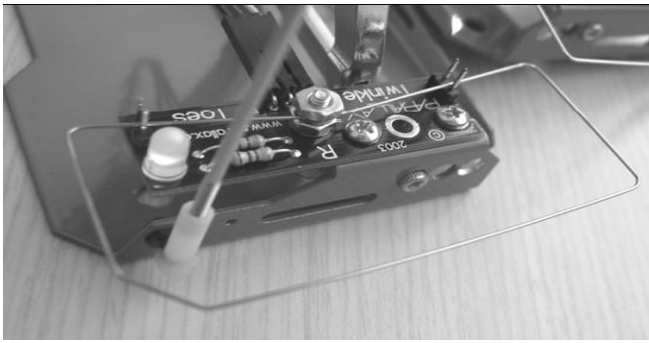

Figure 4. Twinkle Toes from Parallax, Inc.

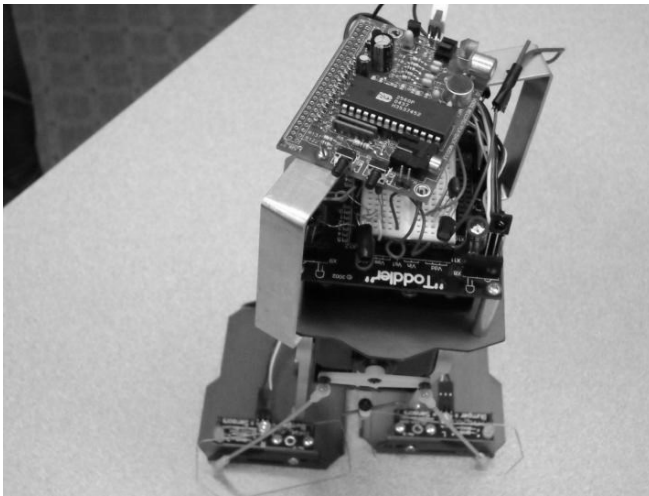

Figure 5. Assembled Toddler Robot with sound module by senior student.

### Faculty's Observation of Peer Teaching and Learning:

The principal faculty had many closed observations and interviews with students involved in this project. The pairing of graduating senior and freshman student in the collaborative design project was fruitful in consideration of the following interaction and observations:

- The project was a decision-making process for the freshman who was undecided between electrical engineering technology and mechanical engineering technology as his major. After completion of this project, he selected mechanical engineering technology.

- At the beginning of the project, the freshman student only assisted the senior student in the assembly of the robot. Programming was done by the senior student only. As time passed, the freshman student became more confident, and performed more hands-on activities and spent more time alone in the laboratory manipulating the Toddler robot.
- The freshman gained a sense of accomplishment by assembling and programming the Toddler Robot.
- The freshman became familiar with using tools and machinery in the laboratory with the direction of the senior student.
- The freshman became confident and was motivated to work alone at times on the projects.
- As a result of this project, the freshman is currently involved in a design project of a hybrid Go-Cart.
- The senior student was a bit nervous when the interfacing of the Toddler with National Instrument was not feasible in a timely manner, but he expressed a feeling of accomplishment upon modifying and completing the project.
- The senior student was in a position of mentoring the freshman. He was happy to assist a fellow student toward achieving successful results.

### Conclusion

The knowledge and experience gained by both students during this project helped them become involved in the application of theoretical materials that are offered in our curriculum. It allowed students to gain experience in the use of the microprocessor to write the software to make a robot have

motion. It provided opportunities for students to have hands on experience in planning, writing up the specs, ordering materials, and constructing the robot. They learned how to make intelligent decisions and/or modifications to the project, and/or to add on more features to operate and maneuver the robot. It was a learning and motivating process for both students, but it was a larger gain of knowledge for the freshman student to collaborate with the graduating senior. The students worked together to discover reasonable solutions to each problem they encountered as the project progressed until its completion.

### **BIBLIOGRAPHY**

1. Floyd T. L. Digital Fundamentals, Tenth Edition, Pearson Prentice Hall, NJ. 2009.
2. Dorf R. C. and Bishop R.H, Modem Control Systems, Eleventh Edition, Pearson Prentice Hall, NJ. 2008.
3. Kheir M., The M 68HC11 Microcontroller application in Control, Instrumentation and Communication, Prentice Hall, N. J., 1997.

### **Biographical Information**

Dr. K. Fotouhi, is a Professor of electrical engineering technology at the University of Maryland Eastern Shore. He received his M.S. from Oklahoma State University and his Ph.D. from the University of Missouri-Rolla. He has published numerous papers in the Electrical and Solid State Physics Fields. He has been involved in joint research in growth and development of new semiconductors and Maryland Off Shore Wind Energy Research. He was the recipient of 1990 University of Maryland Eastern Presidential Distinguished Research Award and he is member of the Eta Kappa Nu Honor Society.